

ECE 303: Electromagnetic Fields and Waves

Fall 2007

Homework 4

Due on Sep. 21, 2007 by 5:00 PM

Reading Assignments:

i) Review the lecture notes.

ii) Relevant sections of the online *Haus and Melcher* book for this week are 8.0-8.2, 8.6, 11.0-11.2. Note that the book contains more material than you are responsible for in this course. Determine relevance by what is covered in the lectures and the recitations. The book is meant for those of you who are looking for more depth and details.

Table of Solutions of Laplace's Equation

Spherical Coordinate System	Cylindrical Coordinate System
$\phi(\vec{r}) = A$ Constant potential	$\phi(\vec{r}) = A$ Constant potential
$\phi(\vec{r}) = \frac{A}{r}$ Spherically symmetric potential	$\phi(\vec{r}) = A \ln(r)$ Cylindrically symmetric potential
$\phi(\vec{r}) = A r \cos(\theta)$ Potential for uniform z-directed E-Field	$\phi(\vec{r}) = A r \cos(\phi)$ Potential for uniform x-directed E-Field
	$\phi(\vec{r}) = A r \sin(\phi)$ Potential for uniform y-directed E-Field
$\phi(\vec{r}) = A \frac{\cos(\theta)}{r^2}$ Potential for point-charge-dipole-like solution oriented along the z-axis	$\phi(\vec{r}) = A \frac{\cos(\phi)}{r}$ Potential for line-charge-dipole-like solution oriented along the x-axis
	$\phi(\vec{r}) = A \frac{\sin(\phi)}{r}$ Potential for line-charge-dipole-like solution oriented along the y-axis

Problem 4.1: (Metal wire over a perfect metal plane)

Consider a thin metal wire of radius a over an infinite perfect metal ground plane, as shown in the figure below. The distance of the wire from the ground plane is much larger than the radius of the wire (i.e. $d \gg a$). The structure is infinite in the z-direction. In this problem you will need to find the **inductance per unit length** (i.e. the length in the z-direction) between the metal wire and the ground plane. The metal wire is assumed to carry a time-varying current I ("time-varying" in the magnetoquasistatic sense) in the +z-direction.

a) Sketch the image metal wire using the method of images. Indicate the orientation and the current that the image wire carries on your sketch.

b) Assuming that the entire current I in the metal wire is carried by a line current at the center of the metal wire, find the vector potential $\vec{A}(\vec{r})$ everywhere in the region outside the perfect metal (use a result in your lecture handouts).

c) Using your result in part (b) above, and the vector potential $\vec{A}(\vec{r})$, write an expression that relates the current I to the magnetic flux per unit length that passes between the metal wire and the ground plane.

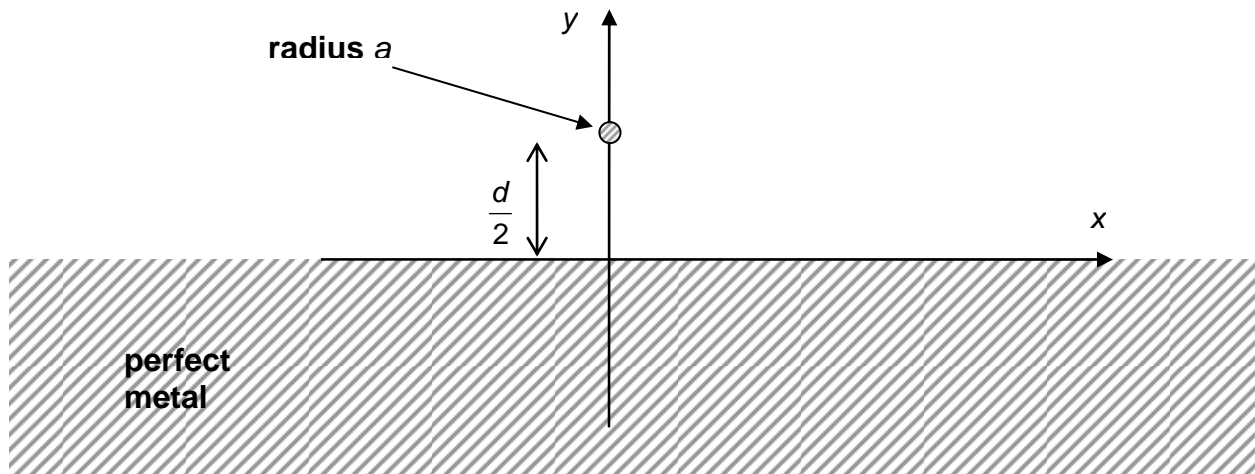

d) Find the inductance per unit length L (units: Henry/m) between the metal wire and the ground plane by taking the ratio of the magnetic flux per unit length (calculated in part (c) above) to the current I .

The last two parts are related to the concept of image currents.

e) If the top metal wire is carrying a time-varying current $I(t)$ ("time-varying" in the magnetoquasistatic sense) in the $+z$ -direction then there must be a position dependent surface current density $\vec{K}(x, t)$ flowing on the surface of the perfect metal. Find this surface current density (magnitude and direction).

f) Integrate the expression for the surface current density found in part (e) above to find the total current that flows on the surface of the perfect metal.

Problem 4.2: (A cylinder with a surface current density)

Consider surface current density on the surface of a cylinder of radius a , as shown in the figure, and given by the expression:

$$\vec{K} = K_0 \cos(\phi) \hat{z}$$

The structure shown in the figure is infinite in the z -direction. You need to find the magnetic field everywhere. One can perhaps use the Biot-Savart law directly but I can imagine the integrations involved will not be pleasant. Instead, you will solve the vector Poisson's Equation directly. Since the current has only a z -component and the structure is infinite in the z -direction, the vector potential will only have a z -component $A_z(r, \phi)$ that is a function of the radial coordinate r and the angle ϕ in cylindrical coordinate system.

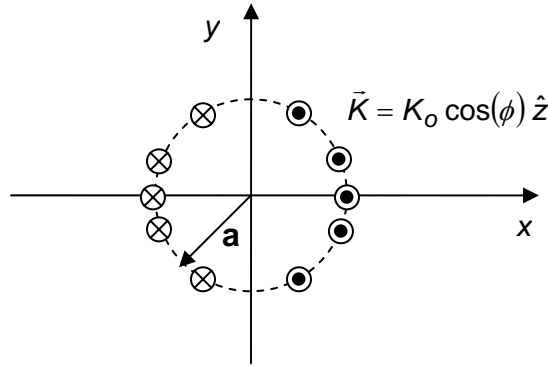

a) Given the vector potential $\vec{A} = A_z(r, \phi) \hat{z}$, write down simplified expressions for the H-field components using the tables at the back of your textbook.

The vector potential satisfies the equation:

$$\nabla^2 \vec{A} = -\mu_0 \vec{J}$$

Since there is no volume current density in the problem – only a surface current density - and since the vector potential has only a z-component the above equation becomes:

$$\nabla^2 A_z = 0$$

So the z-component of the vector potential satisfies the Laplace's Equation.

b) Write down trial solutions $A_z^{in}(r, \phi)$ and $A_z^{out}(r, \phi)$ for $r < a$ and $r > a$ that go to zero at infinity and do not blow up at the origin. Your solutions should have undetermined constants.

c) The inside and outside solutions must be “stitched” at $r = a$ by using the boundary conditions on the components of the H-field normal and tangential to the surface of the cylinder. What are these boundary conditions in terms of the vector potentials $A_z^{in}(r, \phi)$ and $A_z^{out}(r, \phi)$?

d) Use the boundary conditions in part (c) to find all the unknown constants in your solution of part (b).

e) Write down the final expressions for all the components of the H-field.

f) Sketch the magnetic field lines inside and outside the cylinder.

Problem 4.3: (Electromagnetic induction)

a) Consider a perfect metal wire in the form of a loop. A magnetic field pointing in the +z-direction passes through the center of the loop as shown below. There is a small air gap of length a in the metal wire. The magnetic field is time varying and the total magnetic flux through the loop is a function of time and is given by the expression:

$$\lambda(t) = gt$$

The radius of the metal wire loop is c and the diameter of the wire is b , and $a \ll b \ll c$. Find the magnitude as well as direction of the E-field \vec{E} within the air gap in the metal wire.

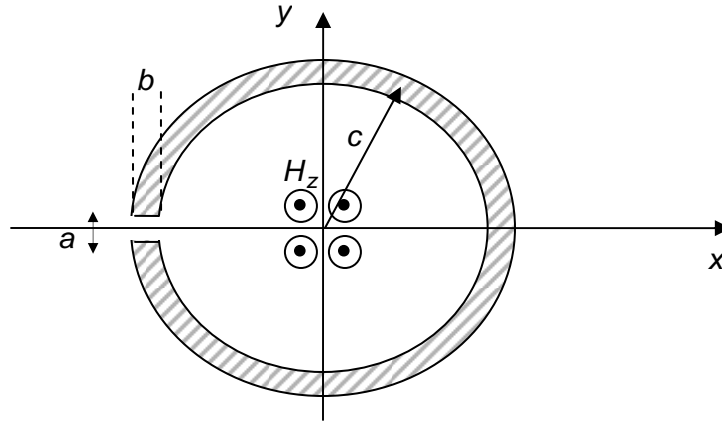

b) Now consider a conductive wire (not a perfect-metal wire) in the form of a loop. A magnetic field pointing in the $+z$ -direction passes through the center of the loop as shown below. The magnetic field is time varying and the magnetic flux through the loop is a function of time and is given by the expression:

$$\lambda(t) = gt$$

The conductivity of the wire material is σ , the radius of the wire loop is c and the diameter of the wire is b , and $a \ll b \ll c$. Find the E-field \vec{E} (magnitude and direction) and the total current I (magnitude and direction) in the wire.

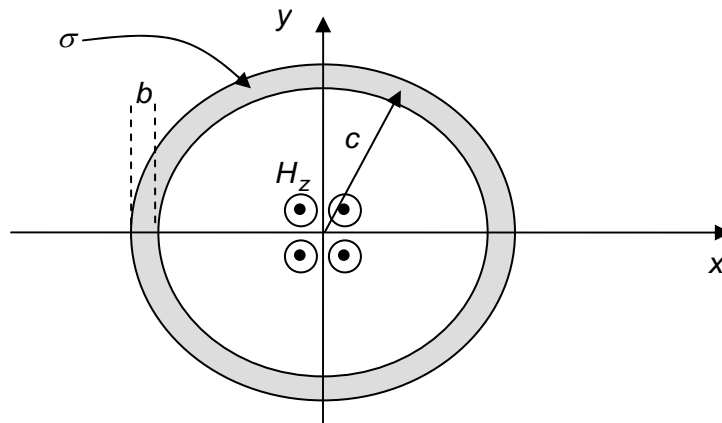

Problem 4.4: (Inductors and electromagnetic induction)

Consider a co-axial cylindrical inductor of length W carrying a time varying current $I(t)$, as shown in the figure below (and also discussed in the lecture notes). The inner cylinder has radius a and the outer cylindrical shell has radius b . The gap between the inner and outer cylinders is closed off by a perfect metallic wall at $z=W$ to provide a return path for the current. You should work in cylindrical co-ordinates in this problem. The magnetic field has only a ϕ -component.

- Find the magnetic field $H_\phi(\vec{r}, t)$ as a function of the current $I(t)$.
- Find the total magnetic flux $\lambda(t)$ enclosed within the inductor as a function of the current $I(t)$.
- Find the inductance L of the inductor using your answer in part (b).

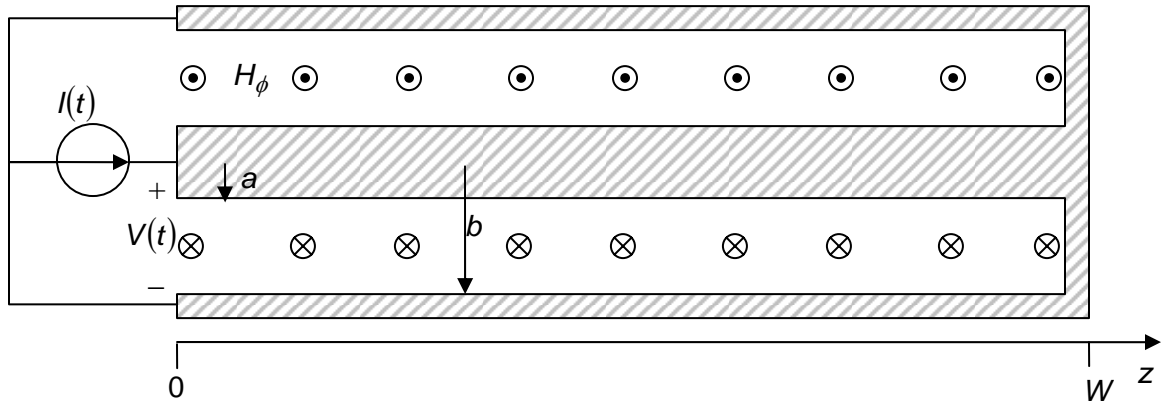

Now comes the interesting part:

d) Circuit theory tells us that if the current is changing with time in an inductor then there should be a measurable voltage $V(t)$ across the two ends of the inductor given by:

$$V(t) = L \frac{dI(t)}{dt}$$

If there is a measurable voltage then there has to be a radial E-field at $z=0$ whose line integral across the input terminals gives the voltage $V(t)$. By using Faraday's law directly and choosing an appropriate contour, verify that the radial component of the E-field at $z=0$ must satisfy:

$$\int_a^b E_r(r, z=0, t) dr = L \frac{dI(t)}{dt}$$

e) Find the time-dependent and the position dependent E-field inside the inner and outer cylinders as a function of the co-ordinate z and the co-ordinate r .

Hints: The E-field must satisfy all perfect metal boundary conditions and also Maxwell's following two equations:

$$\nabla \cdot \vec{E}(\vec{r}, t) = 0 \quad \nabla \times \vec{E}(\vec{r}, t) = -\frac{\partial \mu_0 \vec{H}(\vec{r}, t)}{\partial t}$$

Problem 4.5: (Power dissipation in conductors and Poynting's theorem)

Consider a conductor in the form of a rod of radius a and length L , as shown. The conductor carries a uniform time-periodic current density given by $\vec{J} = J_0 \sin(\omega t) \hat{z}$.

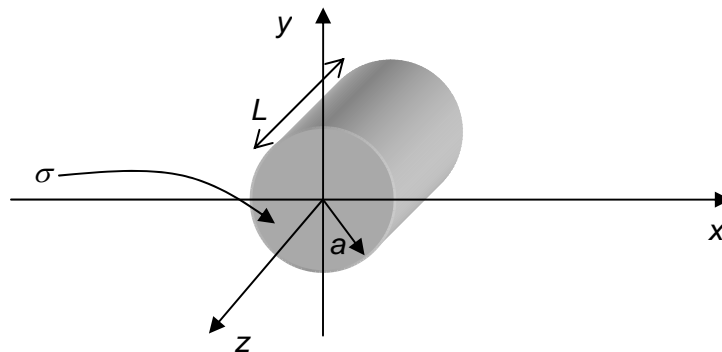

a) Find the time-dependent electric field $\vec{E}(\vec{r}, t)$ within the conductor (Hint: You are not supposed to use Faraday's law here).

b) Find the time-dependent magnetic field $\vec{H}(\vec{r}, t)$ within the conductor. Note that you are working in the magnetoquasistatic limit where the magnetic fields are produced by only electric currents and not by time-varying electric fields.

c) Using your result in (a), find the time-average power dissipation (units: Joules/sec) within the entire volume of the conductor. (Hint: you have to use $\langle \iiint \vec{J}(\vec{r}, t) \cdot \vec{E}(\vec{r}, t) dV \rangle$ where the angled brackets indicate time-averaging over one period T given by, $T = 2\pi/\omega$. Your result for time-average power dissipation will be independent of time). The following formulas might prove helpful:

$$\langle \sin^2(\omega t) \rangle = \frac{1}{T} \int_0^T \sin^2(\omega t) dt = \frac{1}{2} \quad \langle \cos^2(\omega t) \rangle = \frac{1}{T} \int_0^T \cos^2(\omega t) dt = \frac{1}{2}$$

d) Find the total resistance R of the rod and the total time-dependent current $I(t)$ flowing in the rod, and then show that the time-average power dissipation given by $\langle I^2(t)R \rangle$ is the same as that found in part (c) above.

e) Now calculate the time-average electromagnetic energy flow (units: Joules/sec) into the conductor using the Poynting vector (Hint: you need to calculate the surface integral $-\oint (\vec{E}(\vec{r}, t) \times \vec{H}(\vec{r}, t)) \cdot d\vec{a}$ right at the surface of the conductor and then time-average the result over one period).

f) The Poynting's theorem states that:

$$-\oint (\vec{E}(\vec{r}, t) \times \vec{H}(\vec{r}, t)) \cdot d\vec{a} = \frac{\partial}{\partial t} \iiint W(\vec{r}, t) dV + \iiint \vec{J}(\vec{r}, t) \cdot \vec{E}(\vec{r}, t) dV$$

In the present case, when one is dealing with time-periodic fields, the time-average version of Poynting's theorem is:

$$\langle -\oint (\vec{E}(\vec{r}, t) \times \vec{H}(\vec{r}, t)) \cdot d\vec{a} \rangle = \langle \iiint \vec{J}(\vec{r}, t) \cdot \vec{E}(\vec{r}, t) dV \rangle$$

where the angled-brackets indicate time-averaging over one period. Notice that, $\langle \frac{\partial}{\partial t} \iiint W(\vec{r}, t) dV \rangle = 0$

because the fields are periodic in time and the total electromagnetic energy in a closed volume at the beginning and at the end of a period must be the same. Using your results in part (c) and part (e) verify the time-average version of the Poynting's theorem for time-periodic fields.

Problem 4.6: (Dielectric image charge forces)

Consider a point charge $+Q$ sitting in free space at a distance d above a dielectric medium of permittivity ϵ , as shown below. You have already solved this problem in homework 3.

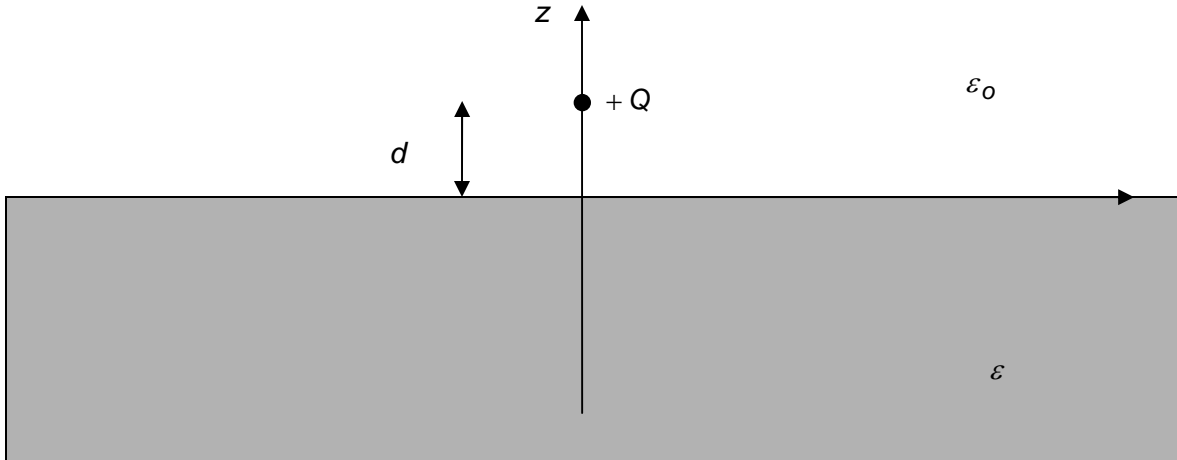

In this problem you will explore the forces exerted by dielectric interfaces on charges. As you have already seen in homework 3, charge density due to paired charges at can exist at dielectric interfaces and this charge density can also exert forces.

a) Using your results from homework 3, calculate the force (magnitude and direction) on the point charge $+Q$. Specify whether the force calculated is repulsive or attractive (i.e. is the point charge $+Q$ being pulled towards the dielectric interface or being pushed away from it).

Now we consider a slightly different spin on the same problem. Consider a point charge $+Q$ sitting inside a dielectric medium of permittivity ϵ at a distance d below the interface, as shown below.

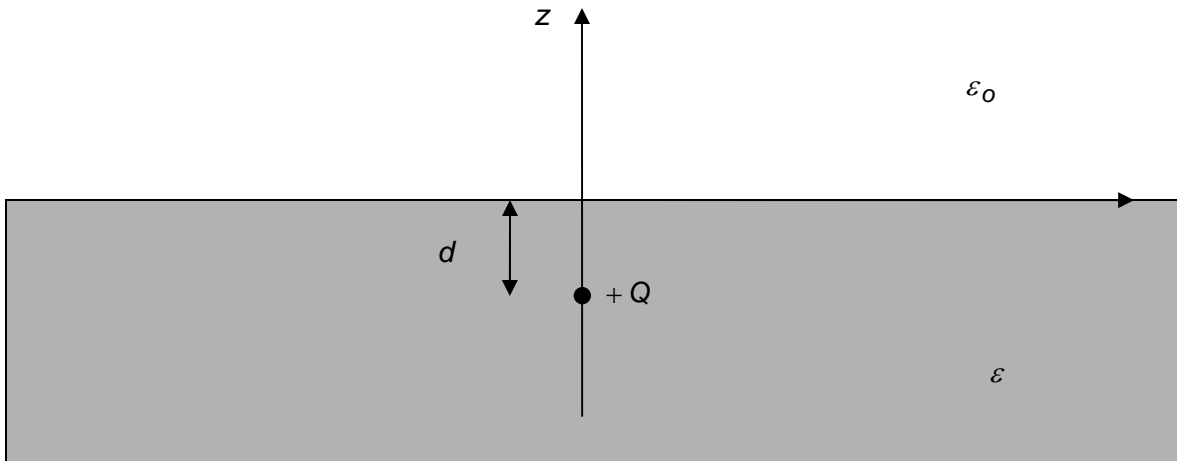

b) Based upon what you learned in homework 3, find expressions for the potential $\phi_{out}(\vec{r})$ outside the dielectric and for the potential $\phi_{in}(\vec{r})$ inside the dielectric.

c) Using your result in part (b), find the net force (magnitude and direction) being exerted on the charge $+Q$. Specify whether the force calculated is repulsive or attractive (i.e. is the point charge $+Q$ being pulled towards the dielectric interface or being pushed away from it).

Bonus Challenge Problem (30 additional points – TAs and Instructors cannot be consulted about this problem):

A perfect metal cylinder of radius a is placed inside a time-varying uniform magnetic field pointing in the x-direction, as shown below. The cylinder is very long (infinite) in the z-direction.

$$\vec{H} = H_0(t) \hat{x}$$

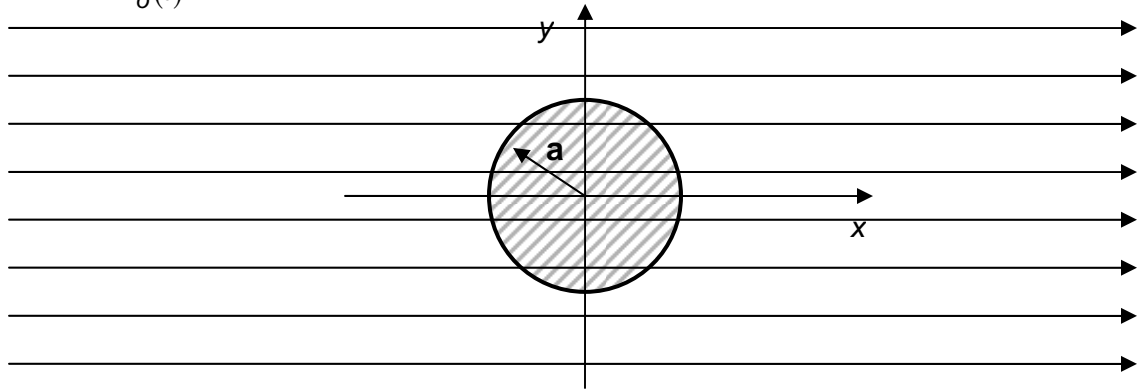

Of course, the actual H-field lines cannot be as shown above since there cannot be a time varying H-field within a perfect metal. Find the actual magnetic field everywhere and sketch it.